

STFCR 10CA-11
STFPR 10CA-11
CTFPR 10CA-11

尺寸相容，相互性強
High interchangeability

解決問題特徵：

- 卡式刀座微調困難。
- 微調精搪頭，單價高。
- 孔段差小於20mm，多層階級孔徑加工。
- 使用微調搪頭，刀桿強度差者。

使用重點：

1. 先將微調螺絲調到下限。
- 2.1. 再調整卡式刀座螺絲至所需尺寸。
3. 刀片損耗之尺寸補正僅需調整微調螺絲。
4. 微調螺絲使用方法參照直接式微調搪刀。

TAIWAN PAT. 132283
USA PAT. 6155753
CHINA PAT. ZL 982 15454.2

DISADVANTAGES OF CONVENTIONAL CUTTING: TOOLS:

- Conventional cartridges are hard to adjust.
 - Micrometrically adjustable fine boring tools are expensive.
 - Step boring is less than 20 mm.
 - Micrometrically adjustable boring tools suffer from poor rigidity at the shank.
- TAIWAN. PAT 132283

CCMT060204/CCGT060202

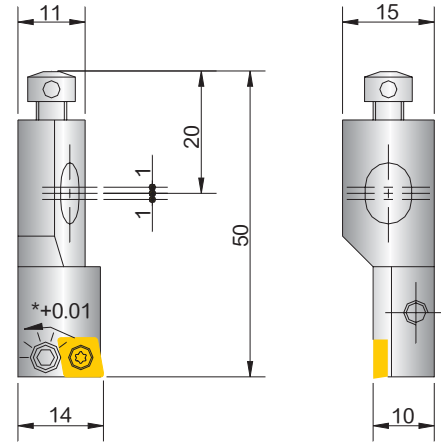
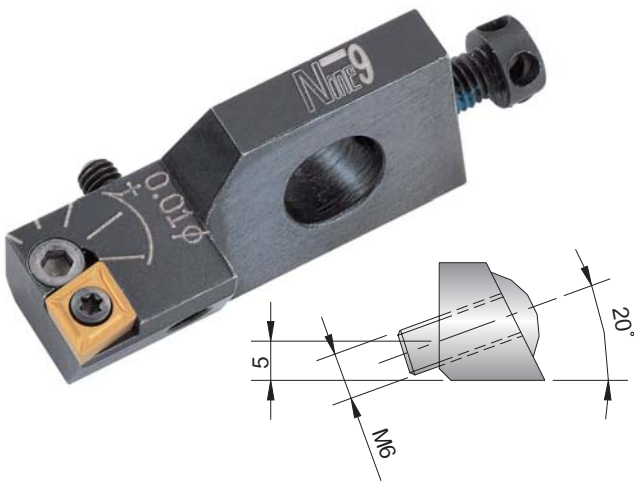

Order No.	Part No.	Insert	取代卡座
99201 - 001	SCFCR 10CA-06MA	CCGT0602	10CA
99201 - 004	SCFCR 08CA-06MA	CCGT0602	08CA
99201 - 005	SCFCR 12CA-09MA	CCGT09T3	12CA

TYPE			
INSERT SIZE	CCMT0602	TCMT0902	TCMT1102
90°	SCFCR 08CA - 06 99211 - 90	STFCR 08CA - 09 99221 - 90	STFCR 10CA - 11 99231 - 90
75°	SCKCR 08CA - 06 99211 - 75	STKCR 08CA - 09 99221 - 75	STKCR 10CA - 11 99231 - 75
60°	SCWCR 08CA - 06 99211 - 60	STWCR 08CA - 09 99221 - 60	STWCR 10CA - 11 99231 - 60
45°	SCSCR 08CA - 06 99211 - 45	STSCR 08CA - 09 99221 - 45	STSCR 10CA - 11 99231 - 45
30°	SCTCR 08CA - 06 99211 - 30	STTCR 08CA - 09 99221 - 30	STTCR 10CA - 11 99231 - 30
15°	SCRCR 08CA - 06 99211 - 15	STRCR 08CA - 09 99221 - 15	STRCR 10CA - 11 99231 - 15
0°	SCGCR 08CA - 06 99211 - 00	STGCR 08CA - 09 99221 - 00	STGCR 10CA - 11 99231 - 00